

Embedded wireless Data Transceiver SV610

1. Description

SV610 is highly-integrated RF module, which adopts high performance Si4432 from Silicon Labs. It comes with TTL interface. SV610 has high sensitivity and 100mW output power to achieve long RF range and reliable RF communication. SV610 comes with many parameters which are configurable, such as: frequency, data rate, output power, Net ID, Node ID. Users can configure the parameters through PC or customer's own device. The features of small size, long distance, wide working voltage and simple parameters configuration make SV610 widely used in many fields.

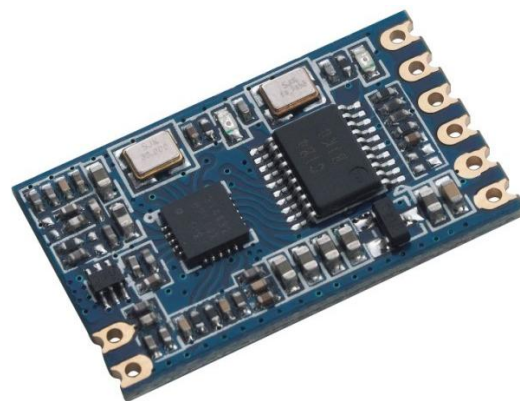

2. Feature

- 433/470/868/915 MHz (Customizable 240-930 MHz)
- Interface: TTL
- 40 channels
- 4 bytes net ID
- 2 bytes node ID
- Multiple air data rate
- GFSK modulation
- Bi-Direction communication
- Parameters configurable
- Parameters saved even powered off
- Sensitivity: -121 dBm
- Max output power: 100 mW
- Voltage: 2.8 ~ 6.0 V
- Temperature: -40 ~ +85 °C

3. Application

- Remote telemetry
 - Auto meter reading
 - Security systems
 - Data logger
 - Wireless data communication
 - Home automation
-

- Healthy monitor
- Wireless PC peripherals
- Access Control
- Robot control

4. Electrical Specifications

Parameter	Min.	Typ.	Max.	Unit	Conditions
Operation conditions					
Supply Voltage	2.8	5.0	6.0	V	
Operating Temperature	-40	25	+85	°C	
Current consumption					
RX Current		25		mA	
TX current		95		mA	@20dBm
Sleep Current		≤5		uA	
RF parameters					
	414.92	433.92	453.92	MHZ	@433MHZ
	470.92	470.92	509.92	MHZ	@470MHZ
	849.92	868.92	888.92	MHZ	@868MHZ
	895.92	914.92	934.92	MHZ	@915MHZ
Air data rate	1.2	9.6	115.2	Kbps	GFSK
Output power	-1	/	+20	dBm	configurable
Sensitivity		-121		dBm	@1.2kbps

Table 1: Electrical Specifications

5. Technical specifications

5.1) Parameters configuration

After pull low the [Set] Pin, SV610 will enter into configuration mode. Then users can set the parameters by PC software or customer's own device with UART interface. The parameters which can be modified include RF channel, air data rate, output power, serial baud rate, data bit, stop bit, parity bit, NET ID and NODE ID. Customer contact the corresponding sales engineer for communication protocol. Below is the PC software

Interface for configuration.

Network Module Communication Tools

Model: SV610 Version: 3.2

CDM5 CLOSE

Net Parameters

NET ID: 00000000 NODE ID: 0000

AUTO ADD 1

Serial Parameters

Baud Rate: 9600 Parity: None

Data bit: 8 Stop: 1

RF Parameters

Band: 433 Data Rate: 9600

Channel: 20 Power: 7

Frequency: 433.92 MHz

SET

READ

DEFAULT

HELP

Alibaba homepage:

Device Found!

Table 2: PC software Interface

Parameter	Option	Default Value
Frequency	433MHz Band	433.92MHz
	470MHz Band	470.92MHz
	868MHz Band	868.92MHz
	915MHz Band	915.92MHz

Channel	1~40	20
Air data rate	1200/2400/4800/9600/14400/19200/38400 /57600/76800/115200 bps	9600
Output power level	0~7 level	7
UART baud rate	1200/2400/4800/9600/14400/19200/38400 /57600/76800/115200 bps	9600
UART Data bit	7, 8, 9	8
UART stop bit	1, 2	1
UART parity	No、Odd、Even	None

Table 3: Parameters Specifications

5.2) RSSI function

The received RSSI value can be read out by command in configuration mode.

5.3) Data communication

SV610 is in working mode when CS Pin stays open or pulls high. It will start to send the data via UART after received the wireless data and verified correctly. And it will start RF transmitting after received the data and verified correctly from UART interface.

In order to achieve the best communication, user should pay attention to the following tips:

5.3.1) Frequency

The frequency (channel and Band) and RF data rate in TX and RX must be set to same value, or it can't communicate with each other.

5.3.2) Net ID

The module comes with a 4-byte Net ID and a 2-byte Node ID. During the period of communication, the Rx will compare the received Net ID with the Net ID of itself, if both NET ID is same, the communication succeed, it goes to next stage, if the NET ID of the RX is set to 0000, it won't do this comparison and goes to next stage. If both Net ID is different and the Net ID of the RX is not 0000, this comparison failed, the Rx won't receive the data from this transmitter.

5.3.3) Node ID

Each module can be set with a unique Node ID. It can be considered as the name of the module. The Node ID can be read out/ modified by PC software or customer's device with

UART Interface.

The Node ID is useful in communication. User can put the Node ID into the data payload, then Rx will find the Node ID of the transmitter from the data packet, so it can identify who is transmitting.

5.3.4) Transmission packet length

For this module, 56 bytes of series data will be packed into one packet for wireless transmission. If the incoming series data is longer than 56 bytes, it will be packed into several packets. The module will start to transmit once got 56 bytes of data from serial port. If no enough data to be one full packet, it will wait until timeout and then start to transmit.

5.3.5) FiFo

The module has a 250-bytes FiFo. If the input serial packet length is less than 250 bytes, the communication runs smoothly without any limitation. If the RF data rate is larger than the Serial data rate, then there is no limitation for serial packet length. Blow is the details for different input serial data length.

Input Serial data length (bytes)	Communication	Remark
≤ 250	Good	No limitation
> 250	Good	RF Data rate $>$ serial data rate
	Some data loss	RF Data rate \leq serial data rate

Table 4: communication with different input serial data length

5.3.6) Sleep Mode

The module enters into sleep mode when CS pin is pulled low, user can waken up the module by pulling high CS Pin. In Sleep mode, the module can't do any communication and cant' be configured even Set Pin is pulled low. The power consumption is low to 5uA in this mode.

6. Accessories

6.1) Antenna

The antenna is important in the communication. For this module, the match impedance is 50 Ohm. We have many kinds of antenna for customer to choose, please contact the corresponding sales engineer for help, or find the antenna in our website.



6.2) USB Bridge Board

The USB Bridge is useful for customers to configure the parameters and simply to do communication test with PC. SU108 -TTL is for TTL Interface module SV610.



SUB108-TTL

7. Schematic

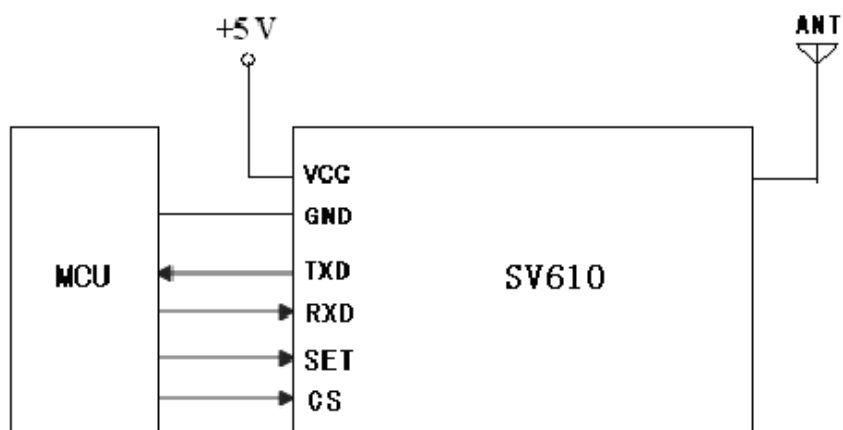

8. Pin Configuration

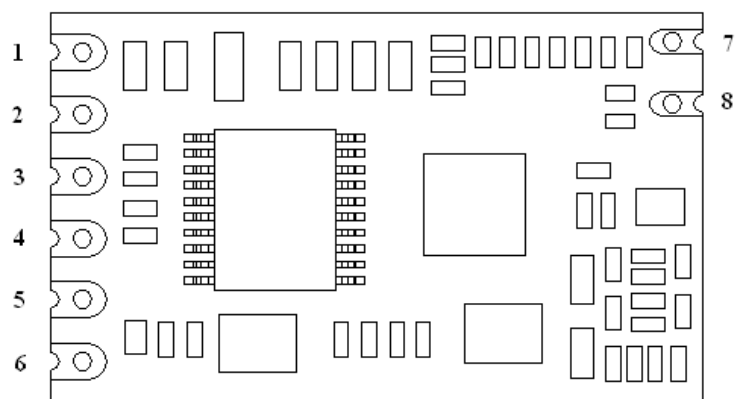

Pin No.	Definition	Description
1	VCC	Connected to the positive power supply (typical 5V)
2	GND	Connected to ground
3	TXD	TXD of the module and connect to external RXD
4	RXD	RXD of the module and connect to external TXD
5	SET	Configuration mode enable (low to enter into the configuration mode, leave open or connect high level to exit configuration mode) Valid when CS Pin is high or leave open.
6	CS	Module working Enable (Pull Low to make the module enter into sleep mode, Leave open or connect high level make the module Enter into normal working mode)
7	GND	Connected to ground
8	ANT	Antenna (50 ohm coaxial antenna)

9. Mechanism dimensions

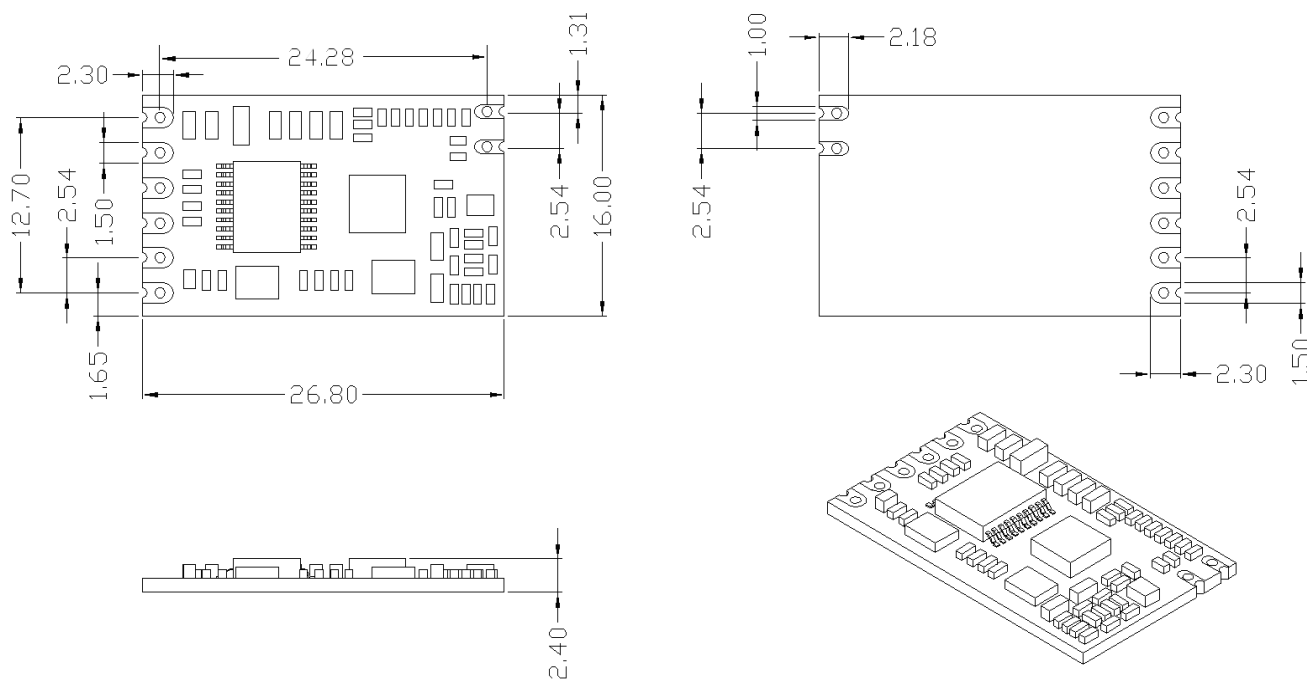

10. Product Ordering Information

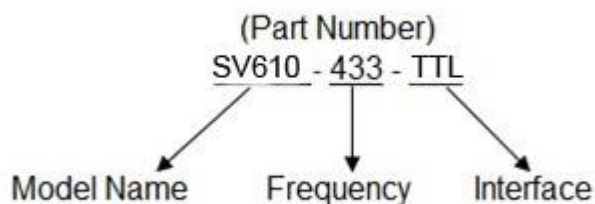

For example:

If the customer needs 433MHZ band with TTL Interface then part number of released order shall be: SV610-433-TTL

Product Name	Description
SV610- 433-TTL	433MHZ, TTL interface
SV610- 470-TTL	470MHZ, TTL interface
SV610- 868-TTL	868MHZ, TTL interface
SV610- 915-TTL	915MHZ, TTL interface

Table 4: SV610 product list

11. Q&A

A) Can't communicate?

- 1) Check if the band, channel, data rate, NET ID is set correctly;
- 2) Check if the power supply is connected correctly ;
- 3) Check if CS is pull high or Leave Open;
- 4) Check if the antenna is connected correctly;

B) Communication distance is not so far as expected?

- 1) Check if the Power supply is stable ;
- 2) Check if the antenna well matched and install properly;
- 3) Check if the surrounding environment is good, if strong interference exist;

C) Data received incorrectly?

- 1) Check if serial data rate, parity and serial data bit are set correctly;
-