

Embedded network module SNR611

1. Description

SNR611 is highly-integrated RF module, which adopts high performance Si4432 from Silicon Labs. It has 3 optional Interface (TTL, 232, 485). SNR611 has high sensitivity and 100mW output power to achieve long RF range and reliable RF communication. SNR611 comes with many parameters which are configurable, such as: frequency, data rate, output power, Net ID, Node ID. Users can configure the parameters through PC or customer's own device. The features of small size, long distance, wide working voltage and simple parameters configuration make SNR611 wildly used in many fields.

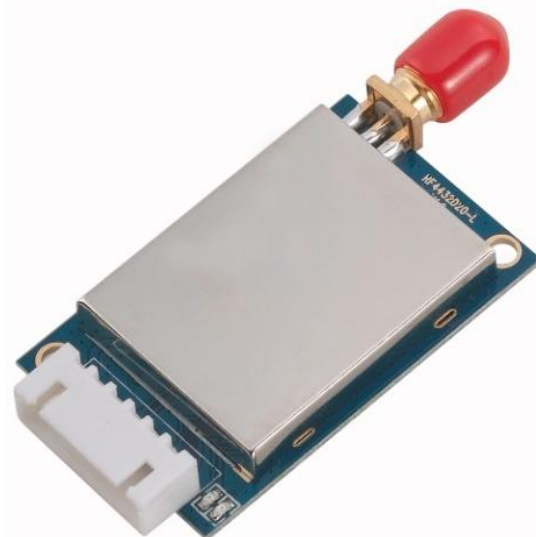

2. Feature

- 433/470/868/915 MHz (Customizable 240-930 MHz)
- Interface: TTL/RS232/RS485 (Optional)
- 40 channels
- 4 bytes net ID
- 2 bytes node ID
- Multiple air data rate
- GFSK modulation
- Bi-Direction communication
- Parameters configurable
- Parameters saved even powered off
- Sensitivity: -121 dBm
- Max output power: 100 mW
- Voltage: 2.8 ~ 6.0 V / TTL
- Voltage: 4.5 ~5.5 V / 232,485
- Temperature: -40 ~ +85 °C

3. Application

- Remote telemetry
 - Auto meter reading
 - Security systems
 - Data logger
 - Wireless data communication
 - Home automation
-

- Healthy monitor
- Wireless PC peripherals
- Access Control
- Robot control

4. Electrical Specifications

Parameter	Min.	Typ.	Max.	Unit	Conditions
Operation conditions					
Supply Voltage	2.8	5.0	6.0	V	TTL interface
	4.5	5.0	5.5	V	232/485 interface
Operating Temperature	-40	25	+85	°C	
Current consumption					
RX Current		25		mA	TTL interface
		34		mA	485 interface
		32.7		mA	232 interface
TX current		95		mA	@20dBm
Sleep Current		≤5		uA	@TTL interface
RF parameters					
Frequency	414.92	433.92	453.92	MHZ	@433MHZ
	470.92	470.92	509.92	MHZ	@470MHZ
	849.92	868.92	888.92	MHZ	@868MHZ
	895.92	914.92	934.92	MHZ	@915MHZ
Air data rate	1.2	9.6	115.2	Kbps	GFSK
Output power	-1	/	+20	dBm	configurable
Sensitivity		-121		dBm	@1.2kbps

Table 1: Electrical Specifications

5. Technical specifications

5.1) Parameters configuration

After pull low the [Set] Pin, SNR611 will enter into configuration mode. Then users can set the parameters by PC software or customer's own device with UART interface. The

parameters which can be modified include RF channel, air data rate, output power, serial baud rate, data bit, stop bit, parity bit, NET ID and NODE ID. Customer contact the corresponding sales engineer for communication protocol. Below is the PC software Interface for configuration.

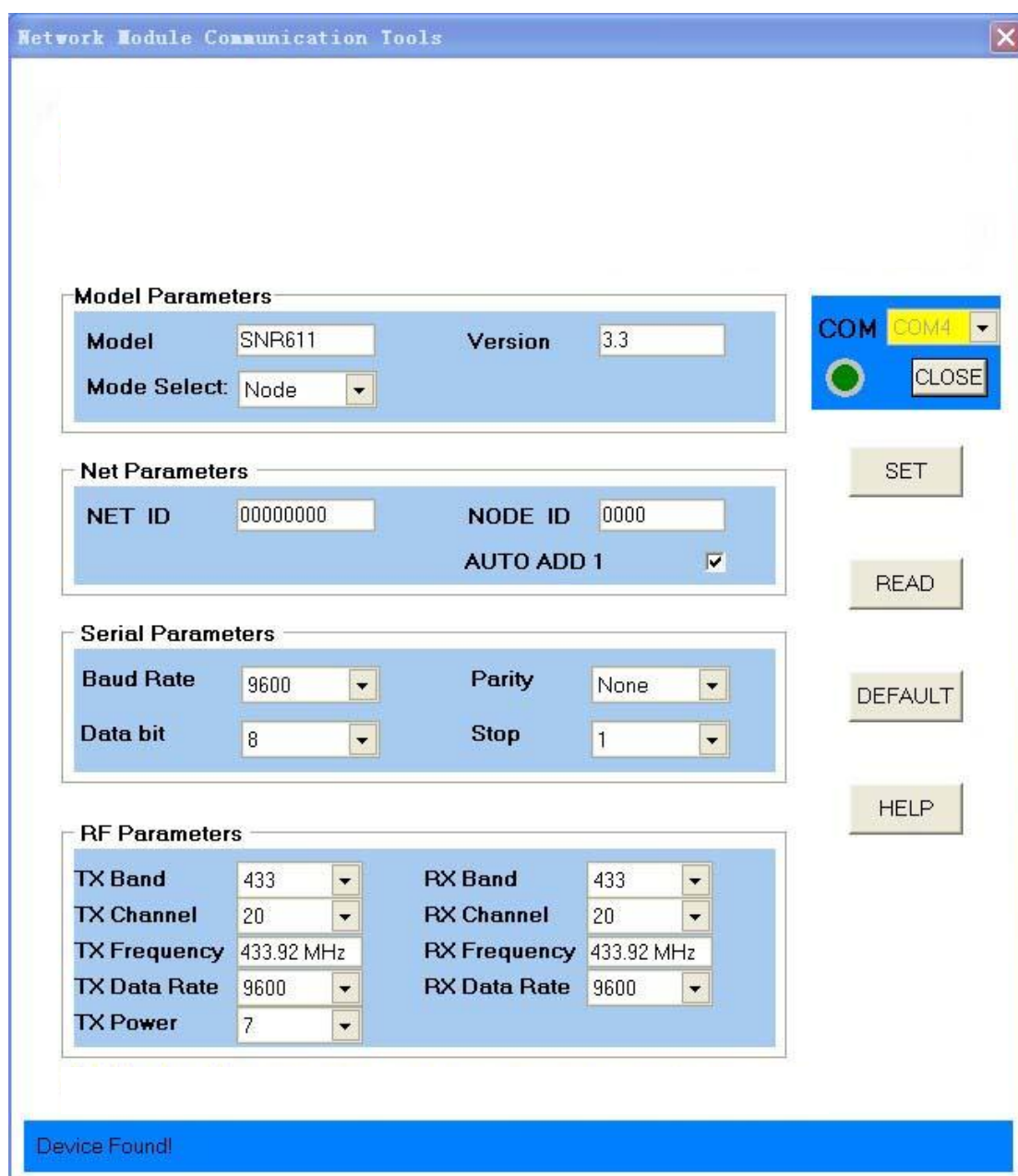

Table 2: PC software Interface

Parameter	Option	Default Value
TX Frequency	433MHz Band	433.92MHz
	470MHz Band	470.92MHz
	868MHz Band	868.92MHz
	915MHz Band	915.92MHz
RX Frequency	433MHz Band	433.92MHz
	470MHz Band	470.92MHz
	868MHz Band	868.92MHz
	915MHz Band	915.92MHz
Channel	1~40	20
TX data rate	1200/2400/4800/9600/14400/19200/38400bps/ 57600bps/76800bps/115200bps	9600
RX data rate	1200/2400/4800/9600/14400/19200/38400bps/ 57600bps/76800bps/115200bps	9600
Output power level	0~7	7
UART baud rate	1200/2400/4800/9600/14400/19200/38400bps/ 57600bps/76800bps/115200bps	9600
UART Data bit	7, 8, 9	8
UART stop bit	1, 2	1
UART parity	No, Odd, Even	None

Table 3: Parameters specifications

5.2) RSSI function

The received RSSI value can be read out by command in configuration mode.

5.3) Data communication

SNR611 is in working mode when CS Pin stays open or pulls high. It will start to send the data via UART after received the wireless data and verified correctly. And it will start RF transmitting after received the data and verified correctly from UART interface.

In order to achieve the best communication, user should pay attention to the following tips:

5.3.1) Frequency

The frequency (channel and Band) and RF data rate in TX and RX must be set to same value, or it can't communicate with each other.

5.3.2) Net ID

The module comes with a 4-byte Net ID and a 2-byte Node ID. During the period of communication, the Rx will compare the received Net ID with the Net ID of itself, if both NET ID is same, the communication succeed, it goes to next stage, if the NET ID of the RX is

set to 0000, it won't do this comparison and goes to next stage. If both Net ID is different and the Net ID of the RX is not 0000, this comparison failed, the Rx won't receive the data from this transmitter.

5.3.3) Node ID

Each module can be set with a unique Node ID. It can be considered as the name of the module. The Node ID can be read out/ modified by PC software or customer's device with UART Interface.

The Node ID is useful in communication. User can put the Node ID into the data payload, then Rx will find the Node ID of the transmitter from the data packet, so it can identify who is transmitting.

5.3.4) Transmission packet length

For this module, 56 bytes of series data will be packed into one packet for wireless transmission. If the incoming series data is longer than 56 bytes, it will be packed into several packets. The module will start to transmit once got 56 bytes of data from serial port. If no enough data to be one full packet, it will wait until timeout and then start to transmit.

5.3.5) FiFo

The module has a 250-bytes FiFo. if the input serial packet length is less than 250 bytes, the communication runs smoothly without any limitation. If the RF data rate is larger than the Serial data rate, then there is no limitation for serial packet length. Blow is the details for different input serial data length.

Input Serial data length (bytes)	Communication	Remark
≤ 250	Good	No limitation
> 250	Good	RF Data rate $>$ serial data rate
	Some data loss	RF Data rate \leq serial data rate

Table 4: communication with different input serial data length

5.3.6) Sleep Mode

The module enters into sleep mode when CS pin is pulled low, user can waken up the

module by pulling high CS Pin. In Sleep mode, the module can't do any communication and can't be configured even Set Pin is pulled low. The power consumption is low to 5uA in this mode.

6. Router / Node Function

SNR611 can be set as Node or Router by PC software or user device. When it is set as Node, it can get data from UART then transmit out with RF or get data from RF then transmit out with UART. When it is set as Router, it works as a Router or Repeater. It won't receive data from UART and won't transmit data from UART. After got the RF data, it will transmit out with RF in another set channel. With this method, user can extend the distance of node. For details, please contact the responding sales engineer.

7. Accessories

7.1) Antenna

The antenna is important in the communication. For this module, the match impedance is 50 Ohm. We have many kinds of antenna for customer to choose, please contact the corresponding sales engineer for help, or find the antenna in our website.



7.2) USB Bridge Board

The USB Bridge is useful for customers to configure the parameters and simply to do communication test with PC. There are 3 types of USB Bridge, which are SU108-TTL, SU108-232, SU108 - 485. SU108 -TTL is for TTL Interface, SU108-232 is for 232 Interface, SU108 - 485 is for 485 Interface:



SUB108-TTL

SUB108-232

SUB108-485

8. Pin Configuration

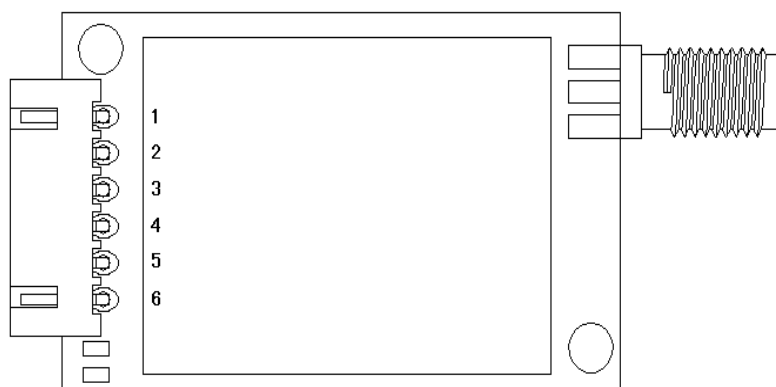

Pin No.	Definition	Description
1	VCC	Connected to the positive power supply (typical 5V)
2	GND	Connected to ground
3	TXD	TXD of the module and connect to external RXD
4	RXD	RXD of the module and connect to external TXD
5	SET	Configuration mode enable (low to enter into the configuration mode, leave open or connect high level to exit configuration mode) Valid when CS Pin is high or leave open.
6	CS	Module working Enable (Pull Low to make the module enter into sleep mode, Leave open or connect high level make the module

		Enter into normal working mode)
--	--	----------------------------------

9. Mechanism dimensions

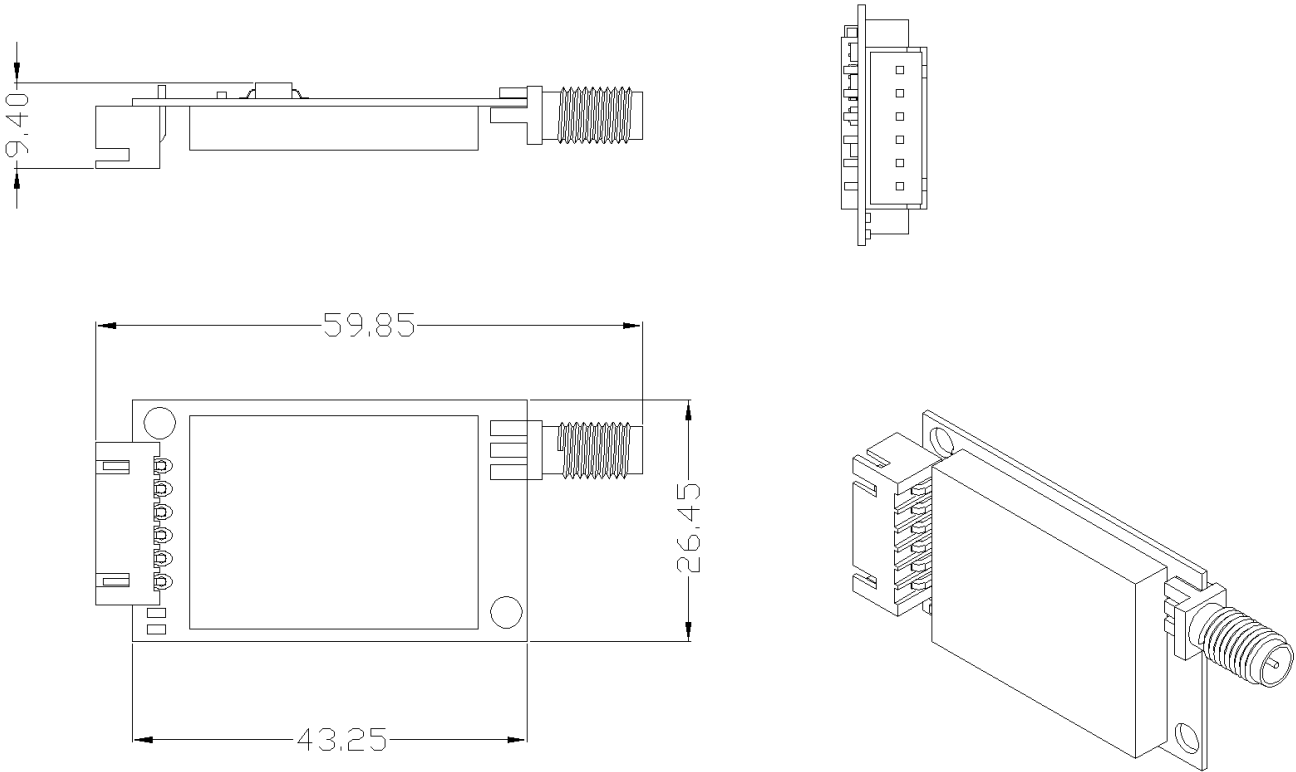

10. Product Ordering Information

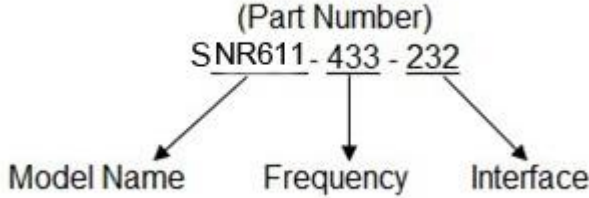

For example:

If the customer needs 433MHZ band with 232 Interface then part number of released order shall be: SNR611-433-232

Product Name	Description
SNR611- 433-TTL	433MHZ, TTL interface
SNR611- 433-232	433MHZ, 232 interface
SNR611- 433-485	433MHZ, 485 interface
SNR611- 470-TTL	470MHZ, TTL interface
SNR611- 470-232	470MHZ, 232 interface
SNR611- 470-485	470MHZ, 485 interface
SNR611- 868-TTL	868MHZ, TTL interface
SNR611- 868-232	868MHZ, 232 interface
SNR611- 868-485	868MHZ, 485 interface
SNR611- 915-TTL	915MHZ, TTL interface
SNR611- 915-232	915MHZ, 232 interface
SNR611- 915-485	915MHZ, 485 interface

Table 4: SNR611 product list

11. Q&A

A) Can't communicate?

- 1) Check if the band, channel, data rate, NET ID is set correctly;
- 2) Check if the power supply is connected correctly ;
- 3) Check if CS is pull high or Leave Open;
- 4) Check if the antenna is connected correctly;

B) Communication distance is not so far as expected?

- 1) Check if the Power supply is stable;
- 2) Check if the antenna well matched and install properly;
- 3) Check if the surrounding environment is good, if strong interference exist;

C) Data received incorrectly?

- 1) Check if serial data rate, parity and serial data bit are set correctly;
-