



LM556

LINEAR INTEGRATED CIRCUIT

DUAL TIMER

DESCRIPTION

The UTC **LM556** dual monolithic circuit is a highly stable controller capable of producing accurate delays or oscillation. The UTC **LM556** is the dual of UTC NE555; timing is provided an external resistor and capacitor for each function. The two timers operate independently of each other, sharing only V_{CC} and GND. The circuits may be triggered and reset on falling wave forms. The output structures may sink or source 200mA.

FEATURES

- *High Current Driver Capability(=200mA)
- *Adjustable Duty Cycle
- *Timing From μ Sec to Hours
- *Temperature Stability of 0.005%/ $^{\circ}$ C
- *TTL Compatible
- *Operates in Both Astable and Monostable Modes

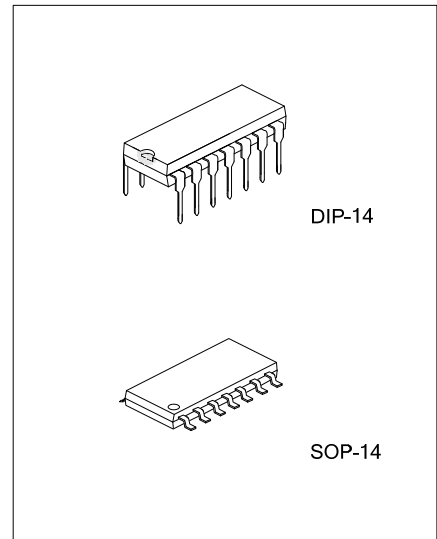

ORDERING INFORMATION

Ordering Number		Package	Packing
Lead Free	Halogen Free		
LM556L-D14-T	LM556G-D14-T	DIP-14	Tube
-	LM556G-S14-R	SOP-14	Tape Reel

<p>LM556L-D14-T</p> <ul style="list-style-type: none"> (1) Packing Type (2) Package Type (3) Green Package 	<ul style="list-style-type: none"> (1) T: Tube, R: Tape Reel (2) D14: DIP-14, S14: SOP-14 (3) L: Lead Free, G: Halogen Free and Lead Free
---	--

MARKING

DIP-14	SOP-14
<p>14 13 12 11 10 9 8 → Date Code UTC □□□□ LM556 □ □□ → Lot Code 1 2 3 4 5 6 7</p>	<p>14 13 12 11 10 9 8 → Date Code UTC □□□□ LM556G □□ → Lot Code 1 2 3 4 5 6 7</p>

■ BLOCK DIAGRAM

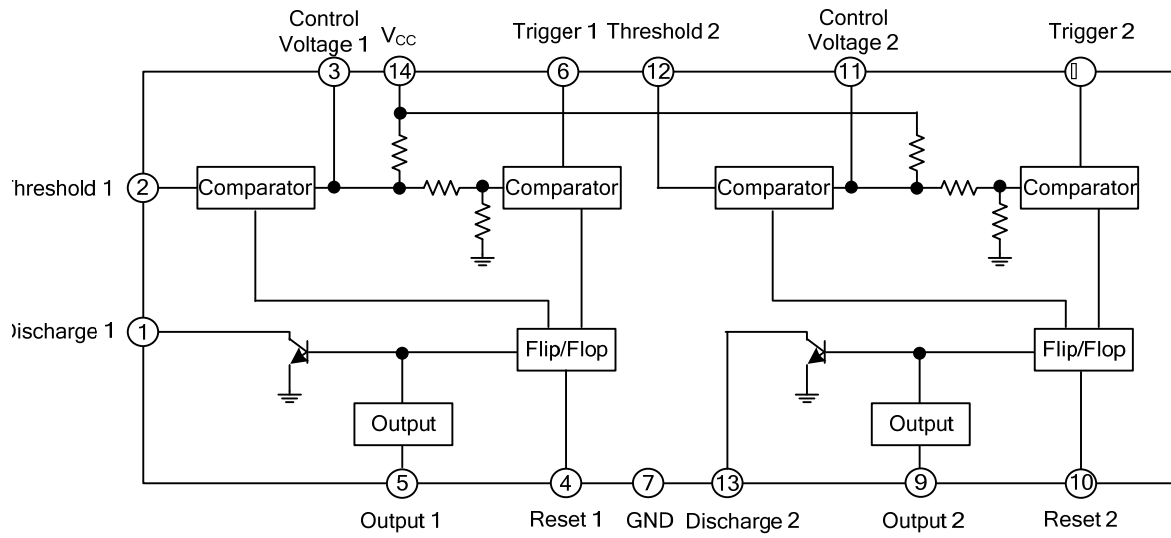

■ ABSOLUTE MAXIMUM RATINGS (T_A=25°C, unless otherwise specified)

PARAMETER	SYMBOL	RATINGS	UNIT
Supply Voltage	V _{CC}	16	V
Power Dissipation	P _D	600	mW
Lead Temperature(soldering 10 sec.)	T _{LEAD}	300	°C
Operating Temperature	T _{OPR}	-20~85	°C
Storage Temperature	T _{STG}	-65~150	°C

■ ELECTRICAL CHARACTERISTICS (T_A=25°C, V_{CC}=5 to 15V, unless otherwise specified)

PARAMETER	SYMBOL	TEST CONDITIONS	MIN	TYP	MAX	UNIT
Supply voltage	V _{CC}		4.5		16	V
Supply Current(two timers) (low state), (Note 1)	I _{CC}	V _{CC} =5V, R _L =∞		5	12	mA
		V _{CC} =15V, R _L =∞		16	30	mA
Timing Error(monostable)						
Initial Accuracy(Note 2)	A _{CCUR}	R _A =2KΩ to 100KΩ C=0.1μF, T=1.1RC		0.75		%
Drift with Temperature	Δt/ΔT			50		ppm/°C
Drift with Supply Voltage	Δt/ΔV _{CC}			0.1		%/V
Timing Error(astable)						
Initial Accuracy(Note 2)	A _{CCUR}	R _A =1KΩ to 100KΩ C=0.1μF, V _{CC} =15V		2.25		%
Drift with Temperature	Δt/ΔT			150		ppm/°C
Drift with Supply Voltage	Δt/ΔV _{CC}			0.3		%/V
Control Voltage	V _C	V _{CC} =15V	9.0	10.0	11.0	V
		V _{CC} =5V	2.6	3.33	4.0	V
Threshold Voltage	V _{TH}	V _{CC} =15V	8.8	10.0	11.2	V
		V _{CC} =5V	2.4	3.33	4.2	V
Threshold Current(Note 3)	I _{TH}			30	250	nA
Trigger Voltage	V _{tR}	V _{CC} =5V	1.1	1.6	2.2	V
		V _{CC} =15V	4.5	5	5.6	V
Trigger Current	I _{tR}	V _{IR} =0		0.01	2.0	μA
Reset Voltage(Note 4)	V _{rst}		0.4	0.6	1.0	V
Reset Current	I _{rst}			0.03	0.6	mA
Low Output Voltage	V _{OL}	V _{CC} =15V, I _{SINK} =10mA		0.1	0.25	V
		V _{CC} =15V, I _{SINK} =50mA		0.4	0.75	V
		V _{CC} =15V, I _{SINK} =100mA		2	3.2	V
		V _{CC} =15V, I _{SINK} =200mA		2.5		V
		V _{CC} =5V, I _{SINK} =5mA		0.15	0.25	V
High Output Voltage	V _{OH}	V _{CC} =15V, I _{SOURCE} =200mA		12.5		V
		V _{CC} =15V, I _{SOURCE} =100mA	12.75	13.3		V
		V _{CC} =5V, I _{SOURCE} =100mA	2.75	3.3		V
Rise Time of Output	t _R			100	300	nSec
Fall Time of Output	t _F			100	300	nSec
Discharge Leakage Current	I _{LKG}			20	100	nA
Matching Parameter						
Initial Accuracy(Note 5)	A _{CCUR}	R _A , R _B =1KΩ to 100KΩ C=0.1μF, V _{CC} =15V		1	2	%
Drift with Temperature	Δt/ΔT			10		ppm/°C
Drift with Supply Voltage	Δt/ΔV _{CC}			0.2	0.5	%/V

Notes: 1. Supply current when output is high is typically 1mA less at V_{CC} 5V.

2. Tested at V_{CC}=5V and V_{CC}=15V.

3: This will determine the maximum value of R_A+R_B for 15V operation, The maximum total is R=20MΩ, and for 5V operation the maximum total is R=6.6MΩ.

4: As reset voltage lower, timing is inhibited and then the output goes low.

5: Matching parameters refer to the difference between performance parameters of each timer section in the monostable mode.

UTC assumes no responsibility for equipment failures that result from using products at values that exceed, even momentarily, rated values (such as maximum ratings, operating condition ranges, or other parameters) listed in products specifications of any and all UTC products described or contained herein. UTC products are not designed for use in life support appliances, devices or systems where malfunction of these products can be reasonably expected to result in personal injury. Reproduction in whole or in part is prohibited without the prior written consent of the copyright owner. The information presented in this document does not form part of any quotation or contract, is believed to be accurate and reliable and may be changed without notice.